

THE 2B6— A DUPLEX TRIODE

Another new tube is now added to the list of power output tubes for radio receivers. The 2B6 described below is an outgrowth of the well-known Triple Twin, with all the "bugs" removed. See its rating, given below. A feature of "triple twin" design lies in the value of the output plate resistance, which is also the value of the output load resistance.

L. VAN DER MEL

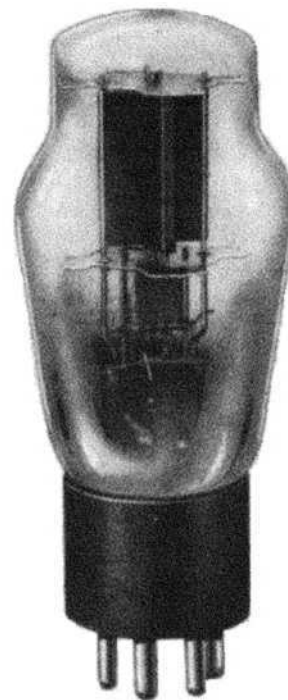

The 2B6—an improved Triple Twin.

IT WAS not long ago when the only output tubes used in radio receivers were triodes, operated in standard class A circuits. The output of a class A arrangement is characterized by high quality and relatively low efficiency. Later, the pentode made its appearance. The pentode, while also of the class A type, has a higher power output and sensitivity for a given plate dissipation than the triode class A; but, unfortunately, the quality is inferior. This is inherently due to the mismatch of the plate impedance to the output load, in order to minimize the distortion. Its optimum load value is critical and the harmonics rise very rapidly with changing load. Furthermore, the predominating harmonic is third which, if large, becomes disagreeable to the ear. Although pentodes may be connected in the push-pull arrangement, the distortion still persists, at a somewhat lower level, but this system does not eliminate the load problems; it is emphasized because, while the second harmonics cancel in a push-pull arrangement, the third and higher order odd harmonics add, especially at high outputs.

Such tubes, however, found much favor among "midget" set manufacturers merely because they permitted large power outputs to be obtained with relatively small signal voltages. In the quest for additional power, class B tubes were designed whose main purpose is to provide very high power output. The system has no improvement

over the pentode with respect to quality, in fact in most applications it is worse. Due to its design complications (particularly the power pack requirements) and its high cost, the system is not readily adaptable to receivers.

THE 2B6

Heater voltage2.5 volts
Heater current2.25 Amp.

INPUT SECTION

Plate voltage250 volts
Grid bias-24 volts
Plate current4 ma.

OUTPUT SECTION

Plate voltage250 volts
Grid bias+2.5 volts
Plate current40 ma.
Plate resistance5,150 ohms
Load resistance5,000 ohms
Signal volts (r. m. s.)25 volts
Power output4 watts

Thus, it is seen that when one wants quality, the triode class A system is the best, while if one wants power output with quality as a secondary object the class B system should be used. For a happy compromise of power, sensitivity, quality, and cost, the pentode has offered the best solution to the problem until the introduction of the new 2B6. The 2B6 consists of two triodes, and is designed to provide high output at low signal voltages in a triode class A connection. Thus, this tube when properly used, is capable of combining the advantages of the high quality found in triode class A systems and the high power output characteristic of class B systems. The results are obtained very economically.

The schematic circuit of this tube is shown in Fig. 1. It is seen that a single heater supplies two separate cathodes, and that the output grid connects directly to the input cathode inside the tube. That triode section of the tube into which the signal is fed is called the input triode, or section; while that section of the tube which feeds the speaker is designated as the output section. The respective elements of each section are labeled accordingly.

An examination of this circuit shows that the grid bias for the input section

is secured by the voltage drop across E_o . Since the steady plate current of this tube is 3 ma. and its self-biasing resistor has a value of 8,000 ohms, the steady D.C. bias is -24 volts. Note that this resistor has no bypass condenser across it. Furthermore, since the input grid is negative with respect to the cathode, no power is dissipated in the input grid circuit.

The output grid connects directly to the cathode as shown, and since the output cathode has a self-biasing resistor of 540 ohms, and since the steady D.C. current of the output section is 40 ma., the voltage drop across this resistor R_1 is 21.5 volts. The actual bias, with no signal at the input grid, therefore, is the difference between the voltage across R_0 and R_1 , +2.5 volts. With this small positive bias, the output grid takes approx 1. ma. current. When a signal is applied to the input section of the tube, an A.C. voltage is impressed on the output grid which, of course, swings this grid alternately more positive and then negative. Since the grid is normally a few volts positive more grid power is consumed when it goes more positive during that part of the cycle. In other words, more grid current is required. This grid power

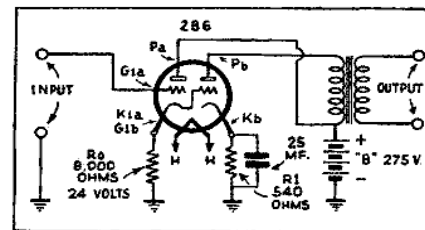

Fig. 1 A
A schematic circuit of the 2B6.

is automatically supplied by the action of the input section. The inherent compensating feature of this particular direct coupling provides the A.C. voltage across R_0 without distortion irrespective of the changing grid resistance of the output section. It is significant to note that the D.C. power taken by the entire tube with no signal is in excess of that required under maximum excitation. Therefore, the tube operates under class A condition and no complications in power pack design are necessary—standard parts may be used. It should also be noted that since the current from the input triode divides, part going through R_0 and part going through the grid-cathode resistance of the output section, the current for determining the input grid bias should be measured between the input cathode and R_0 , not between input plate and "B+."

The resistor R_0 , in addition to supplying the required grid bias for the input section, also acts as the load impedance of the input section and, therefore, cannot be shunted by capacitance. In fact, the total load impedance of the first tube is the parallel combination of R_0 and the grid impedance of the output section.

A particularly significant fact is that although the input grid is biased to -24 volts, a signal of 25 volts r.m.s. is required to deliver the rated output of 4 watts. Although the peak value of the signal applied to the tube is approximately 35 volts, this grid does not draw current because of the degeneration taking place, due to the lack of bypass action across R_0 . This action may be more fully explained as follows.

A signal of 35 volts peak is applied to the input section. As a consequence

of the plate current fluctuation, the A.C. voltage developed across R_0 is 21 volts. Since this voltage is in phase with the signal with respect to ground, the actual peak voltage actuating the input section is 35—21, or 14 volts. This corresponds to an effective value of 10 volts. Since the D.C. bias is -24 volts, the input grid can never draw current. This condition is illustrated by the circuit of Fig. 2 in which the input section has been redrawn so that the signal is applied between input-grid and cathode through the .5-mf. condenser, rather than between input grid and chassis as shown in Fig. 1. In this case, therefore, the signal voltage required for a power output of 4 watts is 10 volts, as calculated previously. Degeneration does not exist in the output section of the tube in view of the fact that R_1 is shunted by a 25 mf. condenser which is more than sufficient to maintain a constant potential across the self-biasing resistor, R_1 .

Alternative Connections

The bias voltage for the output section may be obtained in another manner which has the advantage of eliminating the 25 mf. bypass condenser. Figure 3 shows the circuit arrangement which obviates the use of the bypass condenser. The hum level of the tube is so low that the hum introduced by such an arrangement is still a negligible factor. It is down -30 db which is far below that of more conventional output tubes. This circuit also has the additional advantage of having a slightly better frequency characteristic than that shown in Fig. 1, even though the 25 mf. condenser was increased, in test, to 50 mf.

(Continued on page 167)

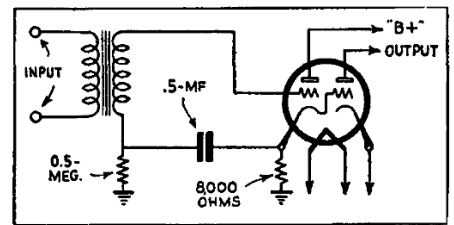

Fig. 2
Feeding the signal from grid to cathode

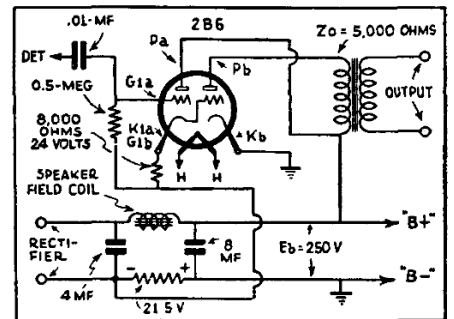

Fig. 3
Eliminating the 25 mf bypass condenser

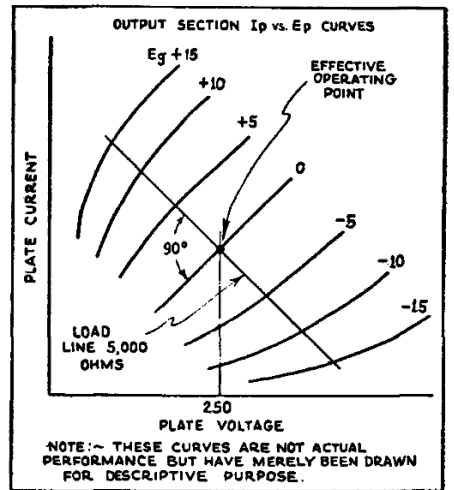

Fig. 6
Plate current vs. plate voltage of the 2B6.

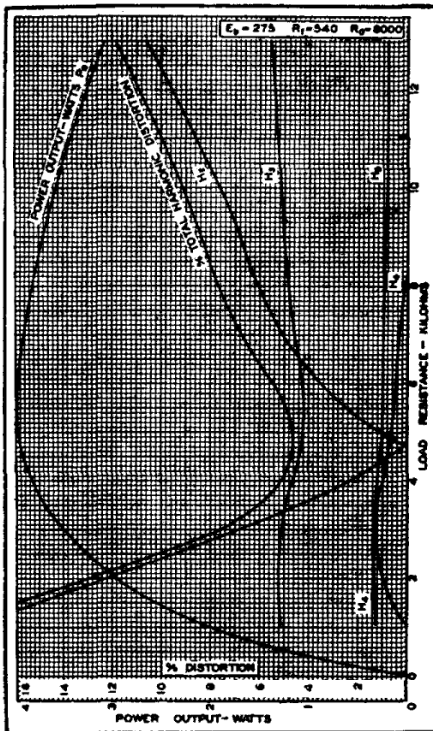

Fig. 4
Curves showing the relation between power output and load resistance.

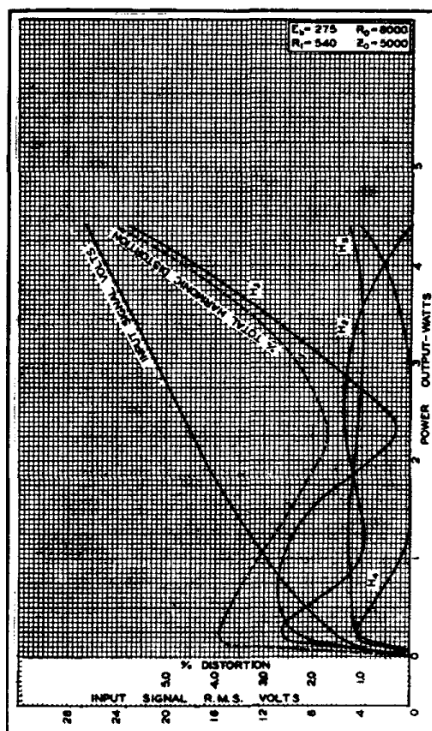

Fig. 5
Distortion vs. power output; and signal volts vs. power output.

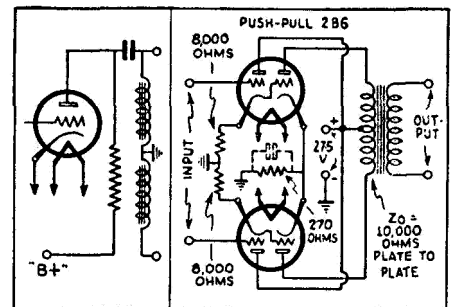

Fig. 7
Two 2B6's in push-pull.

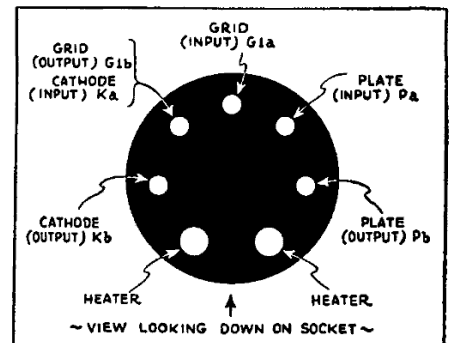

Fig. 8
Socket connections.

THE 2B6 TUBE

(Continued from page 143)

Figure 4 shows the relation between power output and load resistance. An inspection of this curve shows that maximum power output occurs at the same load resistance as minimum total harmonic distortion. In these curves, therefore, an output of 4 watts is secured with a load resistance of 5,000 ohms at a total harmonic distortion of 5%. Figure 5 shows the relation between distortion and power output; also, input signal volts and power. Here again it is seen that at a harmonic content of slightly less than 5% the power output is approximately 4 watts with an input signal of 25 volts r.m.s.

At this point the question arises as to how the output section, which is a triode, is capable of delivering maximum undistorted output to a load impedance which is very nearly equal to its plate impedance, while almost all previous triode class A systems incorporated a load impedance which was twice that of the tube. The explanation for this query may thus be answered by referring to the set of curves shown in Fig. 6. These curves show the relation between plate current and plate voltage. A load line of 5,000 ohms is shown. It is seen that this load line intersects the 2½ volt bias line at right angles and that the extremities of this line intersect the grid voltage curves where the curvatures are opposite; in other words, the load line for example intersects the +15-volt grid curve where the curve is concave downward, while it intersects the -15 volt grid curve where it is concave upward. In this manner, distortion approaching the extremities of the plate voltage swings cancel, thus permitting maximum undistorted output with the load impedance equal to that of the tube. This tube is also well adapted for push-pull operation, and a typical circuit is shown in Fig. 7. A common bias of 270 ohms is required for the output section, and a bypass condenser is not required, although it is recommended for high quality. The characteristics of this tube are as follows:

Input Section

Plate (max) Pa, 250-volts
Grid-G1a +2.5-volts
Plate current, 4.0-ma.
Amplification factor, 7.0
Mutual conductance, 600-micromhos
Plate resistance, 11,650-ohms
Load resistance, 8,000-ohms

Output Section

Plate (max) Pb, 250-volts
Grid-G1b -2.5-volts
Plate current, 40-ma.
Amplification factor, 18
Mutual conductance, 3,500-micromhos
Plate resistance, 5,150-ohms
Load resistance, 5,000-ohms
Signal volts*, 25-volts
Power output**, 4.0-watts

*Volts r.m.s. for rated power.

**5% total harmonic distortion.

Socket connections of this tube are shown in Fig. 8.